

FX-E HD

Forensic Optical



User's Guide



Distributed By:



SIRCHIE

100 Hunter Place, Youngsville, NC 27596
919.544.2244, 800.356.7311
sirchieinfo@sirchie.com

www.sirchie.com

Manufactured by SIRCHIE & Freedom Scientific
Copyright© 2018-2022 SIRCHIE & Freedom Scientific. All Rights Reserved.

Doc ID: FXE-HD_MA09-653ENG-REV7

Published by:



100 Hunter Place, Youngsville, NC 27596

Phone: 919.544.2244, 800.356.7311

Fax: 919.554.2266, 800.899.8181

Email: sirchieinfo@sirchie.com

www.sirchie.com

Information in this document is subject to change without notice. No part of this publication may be reproduced or transmitted in any form or by any means electronic or mechanical, for any purpose, without the express written permission of SIRCHIE.

Copyright© 2018-2022 by SIRCHIE. All Rights Reserved.

Safety and Maintenance

To keep the unit in good condition and to ensure safe usage, observe the following guidelines:

- Do not stare at the operating illumination LED as it may be harmful to the eyes
- Power rating: 100-240VAC ~1A, 47-63 Hz
- Read the instructions in this user's guide before attempting to use the unit.
- Do not attempt to repair the unit or open its case. This product contains no user serviceable parts.
- Keep the unit away from wet areas, rain, and other sources of liquids or high humidity. Do not submerge the unit.
- Always operate the unit in a place where the temperature is between 10° and 40° C (50° and 104° F).
- Always store the unit in a place where the temperature is between -20° and 65° C (-4° and 149° F).
- Always use the unit on a stable, level, hard surface such as a desk or table.
- When cleaning the screen, camera lens, or self-view lens, unplug the power cord and apply a small amount of non-abrasive cleanser, such as the following, to a soft, lint-free cloth and gently wipe:
 - Water
 - Isopropyl alcohol
 - Petroleum benzene
 - Vinegar mixed with water at a concentration of no more than 10 percent vinegar, for example, 1.5 tablespoons of vinegar per cup of water (100 ml per liter)

CAUTION: Do not apply excessive pressure to the screen, camera, or self-view lens. Do not spray cleanser directly on these items. Also, do not use any cleanser that contains the following agents: acetone, ethyl alcohol, ethyl acid, ammonia, or methyl chloride. When cleaning the rest of the unit, make sure the unit is unplugged. Use a lightly dampened, soft, clean cloth with water or mild detergent.

Federal Communications Commission (FCC) Compliance Statement

This device complies with Part 15 of the FCC Rules. Operation is subject to the following two conditions: (1) this device may not cause harmful interference, and (2) this device must accept any interference received, including interference that may cause undesired operation.

This equipment has been tested and found to comply with the limits for a Class B digital device, pursuant to Part 15 of the FCC Rules. These limits are designed to provide reasonable protection against harmful interference in a residential installation. This equipment generates, uses, and can radiate radio frequency energy and, if not installed and used in accordance with the instructions, may cause harmful interference to radio communications. However, there is no guarantee that interference will not occur in a particular installation. If this equipment does cause harmful interference to radio or television reception, which can be determined by turning the equipment off and on, the user is encouraged to try to correct the interference by one or more of the following measures:

- Reorient or relocate the receiving antenna
- Increase the separation between the equipment and receiver
- Connect the equipment into an outlet on a circuit different from that to which the receiver is connected
- Consult the dealer or an experienced radio or television technician for help

CAUTION: Changes or modifications not expressly approved by the party responsible for compliance could void the user's authority to operate the equipment.

Industry Canada (IC) Compliance Statement
CAN ICES-3(B) / NMB-3(B)

Table of Contents

FX-E HD at a Glance.....	3
Hardware Description	5
Rear Panel Connectors.....	5
Transporting and Moving FX-E	6
STEPS TO USE FX-E.....	7
Basic Operation.....	9
Placing Items on the XY Table lacing Items on the XY Table	9
Changing Magnification.....	9
Adjusting Screen and Image Brightness	10
Changing Screen Colors	10
Freezing an Image	10
Using the Find Feature	11
Locking the Focus	11
Advanced Operation.....	12
Focus Lock and Position Locator Beam.....	12
Turning LED Reading Lights On or Off.....	12
Reading Lines, Masks and Shades.....	12
Displaying Lines, Masks, or Shades – Center Switch	13
Moving Lines, Masks, or Shades – Left Wheel	13
Moving a Single Line, Mask, or Shade – Right Wheel.....	13
Using the Reading Line	14
Color Modes	15
Changing Configuration Menu Settings.....	15
Saving and Restoring User Settings.....	17
Restore User Settings	17
Restore User Settings When Powering On the Unit	17
Disabling Center Push Buttons on the Control Panel	18
Resetting Factory Default Settings	18
Displaying Firmware Version Number	19
Appendix A – Configuration Menu Settings.....	20
Appendix B – Adjusting Magnification Settings.....	23
Selecting a Magnification Table.....	23
Changing the Magnification Display Number.....	24
Appendix C – Using FX-E XL HD as a Computer Monitor	25
Screen Resolutions	26
Appendix D – Making a USB Connection to FX-E.....	26
Appendix E – Troubleshooting.....	27
Appendix F – GEM Software User’s Guide.....	28
Freedom Scientific Technical Support for GEM.....	28
Introduction to GEM.....	28
System Requirements	28
Installing GEM	28
Getting Help	29
GEM Hot Keys.....	29
Layered Keystrokes.....	29
Screen View	29
Capture Image	30
View Image.....	31
Zoom and Focus	31
Color Modes	31
Color Adjustments.....	32
Camera Control	32
Lines and Masks	32

The FX-E HD desktop video magnifiers provide clear and sharp magnification of documents, newspapers, photos, and other items. With simple to use controls, you can make quick magnification, color, and brightness adjustments to best suit your vision needs. The high-definition camera produces a clear picture with sharp images and crisp text. This lets you use a lower magnification to maximize the amount of information displayed on the screen. It also reduces the need to move the XY table as much when reading text, looking at pictures, or working with other forensic evidence items.

The FX-E also includes the following features:

- Auto-focus, which creates the clearest view without any need to make adjustments
- 16 magnification levels with a crisp, sharp image that lets you precisely adjust text to the size you need
- Adjustable pre-set color modes for high contrast text that is most comfortable for you
- One-touch button to freeze images
- Widescreen 24-inch monitor
- Adjustable screen brightness
- Lines, masks, and shades that make it easier to concentrate on certain areas of a document, newspaper, magazine, or book
- Create and save custom settings using the Configuration menu
- Adjust the height and angle of the monitor for the best view as well as extra neck and upper back comfort when viewing the screen
- Use the Position Locator beam to mark the center of the image for easy document placement and writing (only)
- Connect your computer through the video port to use the unit as your main computer monitor, and then easily switch back and forth between your computer and the unit's camera view
- Connect and your computer through USB ports to use the optional GEM® image management software to view, capture, and save magnified images from the unit to your computer
- Two lights on either side of the camera provide object illumination, which is diffused to prevent glare and reflections when viewing shiny documents like magazines and photos
- Large low-friction reading table moves a full 16 inches from left to right for easy reading of even large-format documents
- XY table's braking mechanism lets you lock the table movement down tight when you want it to hold steady
- Working distance between XY table and camera: 8.25 inches / 21 cm

The GEM software allows you to use a PC to control the FX-E and capture images from it.

Hardware Description

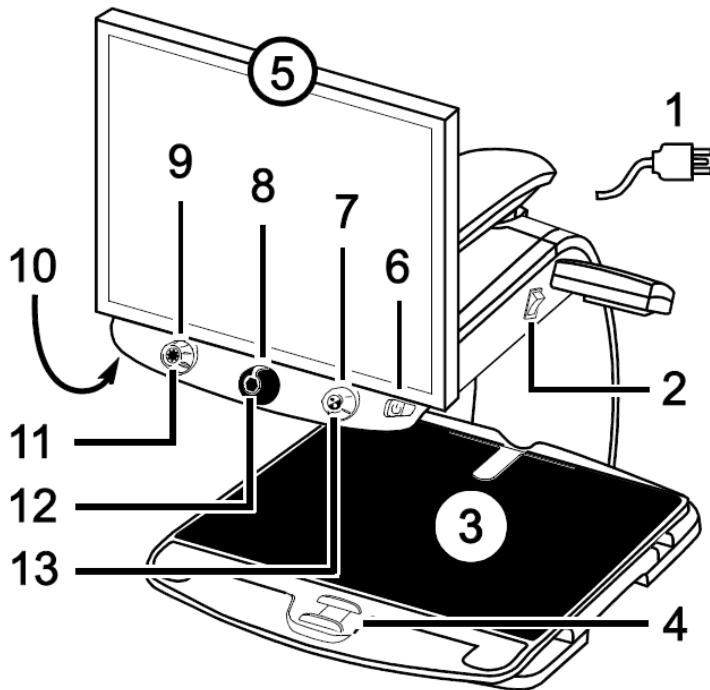

1. Power Cord
2. Main Power Switch
3. XY Table
4. XY Table Brake
5. Monitor
6. Power Button
7. Color Select Dial
8. Magnification Dial
9. Brightness Dial
10. Focus Lock Button—bottom of control panel
11. Find Button
12. Freeze Frame Button
13. Reference Line Button or Computer View Toggle Button*

* Can be connected to a computer and used as a computer monitor. When used this way, the button switches between your computer and the FX-E's camera view.

Rear Panel Connectors

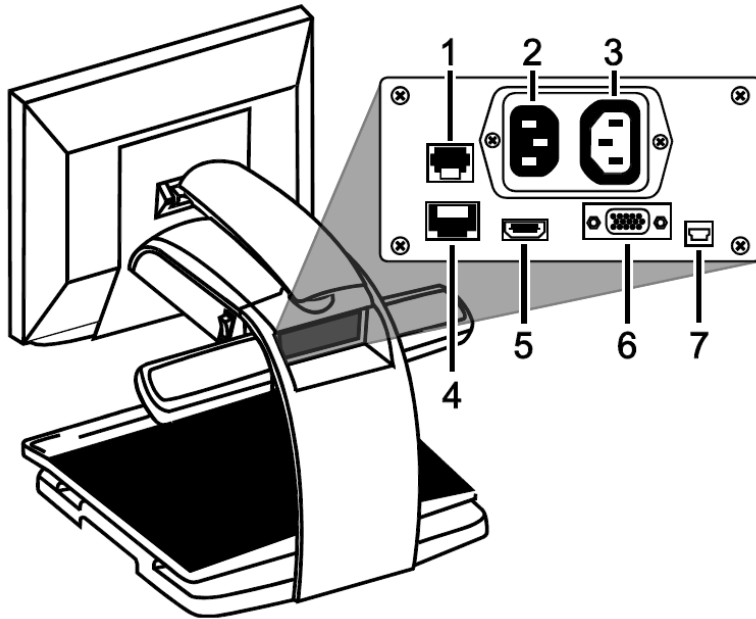

1. **Control panel jack.** Modular jack that connects the control panel to the camera. Do not disconnect cable unless servicing the unit.
2. **AC power connector.** Plug power cord from wall outlet to the unit.
3. **Monitor power connector.** Power cord from monitor to FX-E. There is no need to remove it under normal operation.
4. **Test port.** Do not connect to this port.
5. **Monitor HDMI connector.** Connects the monitor to the camera. There is no need to remove it under normal operation. However, if you later decide to connect a TV or larger monitor to the unit, then use this connector.
6. **VGA In video connector (15-pin).** Connects a computer's video output to the FX-E monitor. The monitor now becomes your computer's display.
7. **USB connector.** Connects a computer to the unit for operation with GEM image management software.

Transporting and Moving FX-E

When carrying and moving the unit, always lock the monitor arm and XY table as described in this section. The unit weighs approximately 44 lbs. (20 kg). Use caution when lifting and carrying the unit.

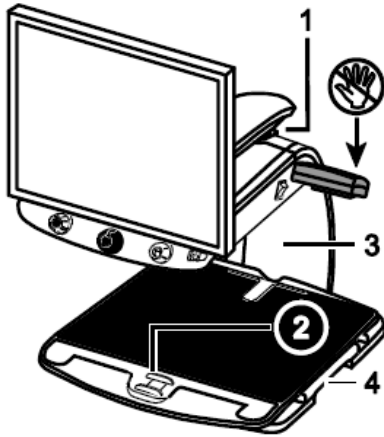

1. Monitor Arm Lock
2. XY Table Brake
3. Rear Post
4. Repositioning Grips

IMPORTANT: Do **NOT** lift the unit by its LED reading lights.

1. Lock the **monitor arm** to secure and prevent the monitor from moving to the left or right.

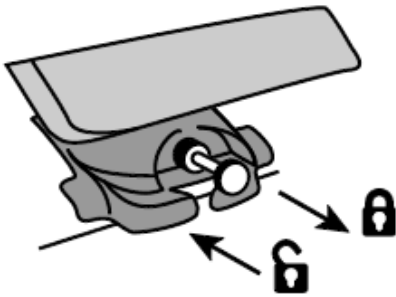

Pull pin out to lock.

Note: Monitor arm must be in the center position before pin locks.

Push pin in to unlock.



2. Lock the **XY table** to stop it from moving by pulling the red brake lock toward you.

3. Lift and carry the unit by the **rear post** (see figure below) to move it to a sturdy surface such as a table, desk, or countertop.

One suggested method is to wrap your forearm around the rear post and then lift.

IMPORTANT: Do **NOT** lift the unit by its LED reading lights.

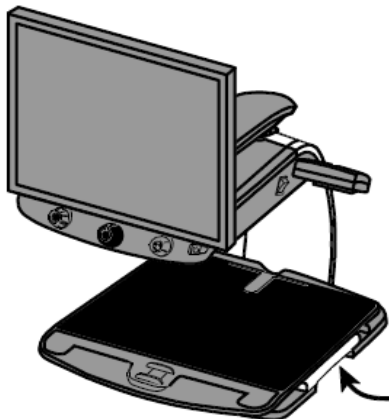

4. Use the **repositioning grips** on both sides of the reading table to move and position the unit to your liking once it is on a sturdy surface.

STEPS TO USE FX-E

1. Plug the **power cord** from the middle power connector on the rear of the FX-E to an electrical wall outlet.

2. Press the white **master power switch** located near the LED reading light on the right side of the FX-E.

3. Press the green **standby power switch** on the right side of the control panel.



Note: If the monitor screen remains blank, make sure that the monitor is turned on.

4. Hold the sides of the monitor with both hands and move it up or down to change the height, or turn the monitor left or right to adjust the angle for the best view.

If the monitor does not move to the left or right, make sure to release the arm lock (push the locking pin in), located at the base of the monitor arm. Also, make sure that the monitor is raised up so that it freely moves from left to right.

For arm unlock information, refer to [Transporting and Moving FX-E](#) as previously mentioned in this document.

5. Place the object that you want to magnify onto the center of the reading table. Move the object back so that it touches the rear of the XY table.

To examine a cylindrical item, such as a pill bottle, place it in the U-shaped indentation located at the rear of the XY table. This prevents the object from rolling around on the table.

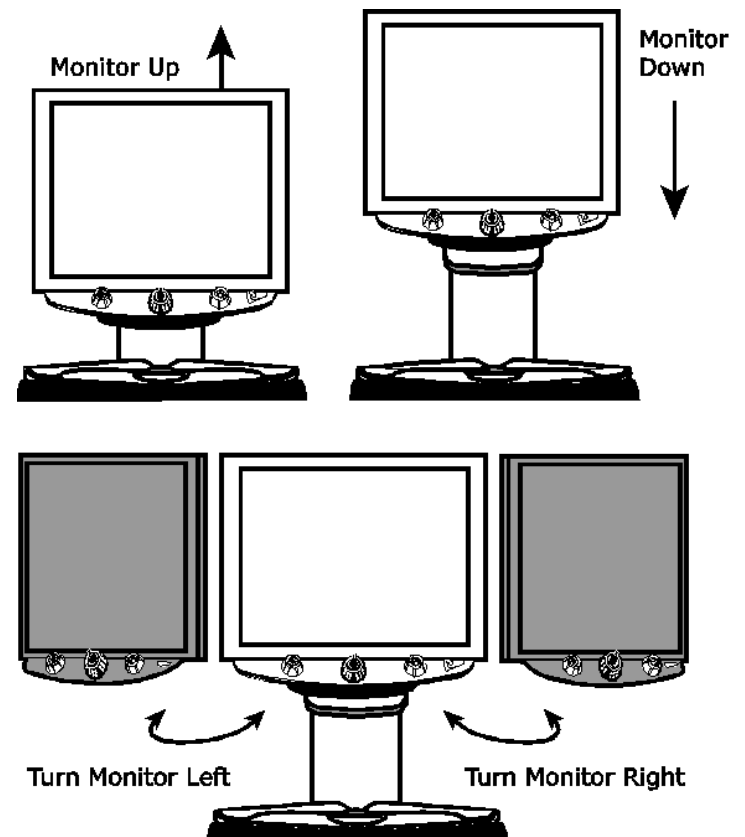
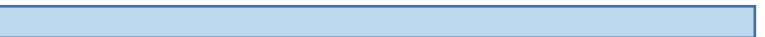
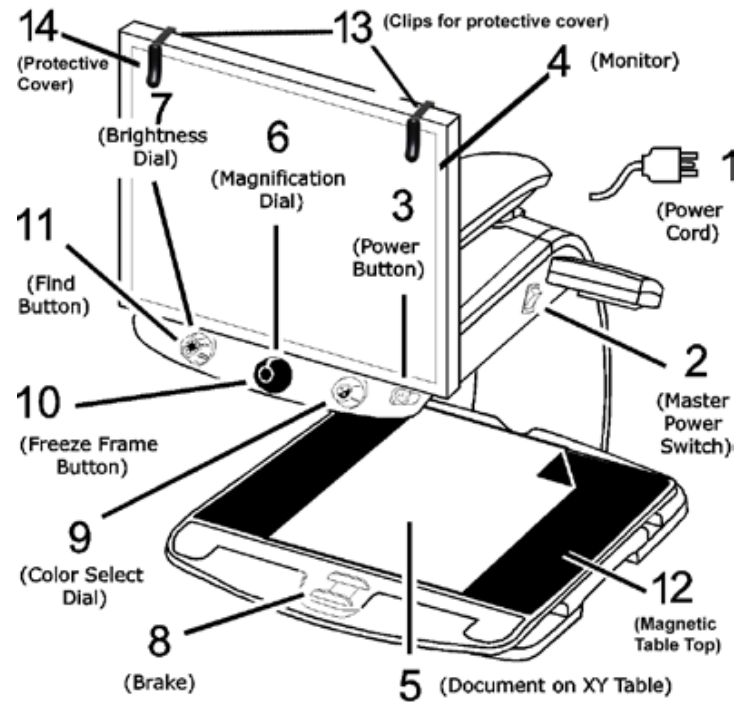

6. Turn the black Magnification dial (illustrated to the right) to adjust magnification.

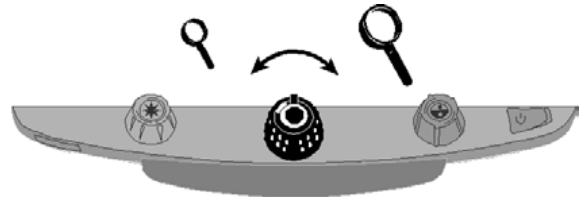

7. Turn the blue/yellow Brightness dial to adjust brightness.

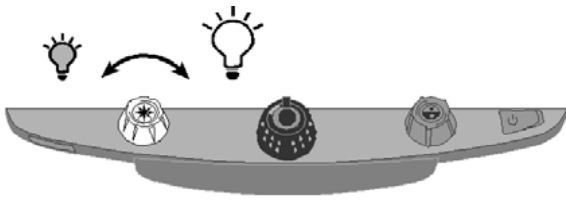

8. Unlock the reading table to move a document so that its text moves back and forth across the screen to make reading easier.

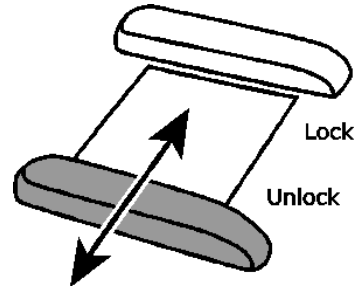

9. Turn the blue Color Select dial (illustrated below) to choose a color mode that best suits your vision needs. Default color modes are full color; black on white; white on black; yellow on blue; and yellow on black.

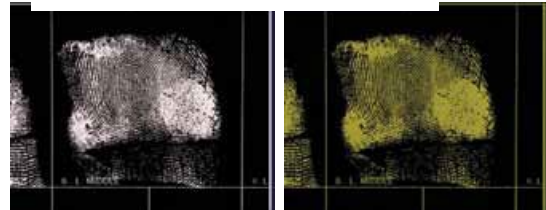

10. Press the Freeze Frame button (illustrated to the right) located in the center of the black Magnification dial to freeze the current image on the screen. Press it again to return to the live view.

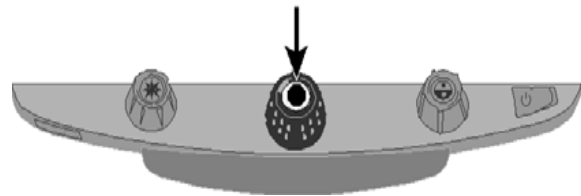

11. Press and hold the Find button located in the center of the yellow Brightness dial to zoom out and see more of the document. A set of crosshairs display on the monitor screen. Move the XY table and use the crosshairs to center and view a new area of the document.

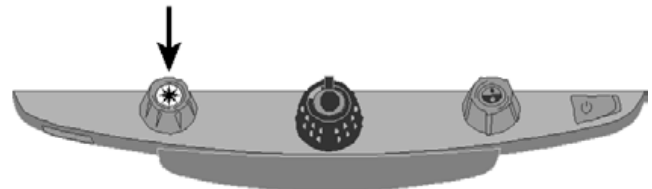

Release the Find button to turn off the crosshairs and zoom back in on the new area of the document.

Placing Items on the XY Table

The following describes how to change magnification and brightness, change color modes, and freeze an image on the screen.

1. Make sure the unit is turned on and that the XY table is visible on the monitor screen.
2. Place the item that you want to magnify onto the center of the reading table.

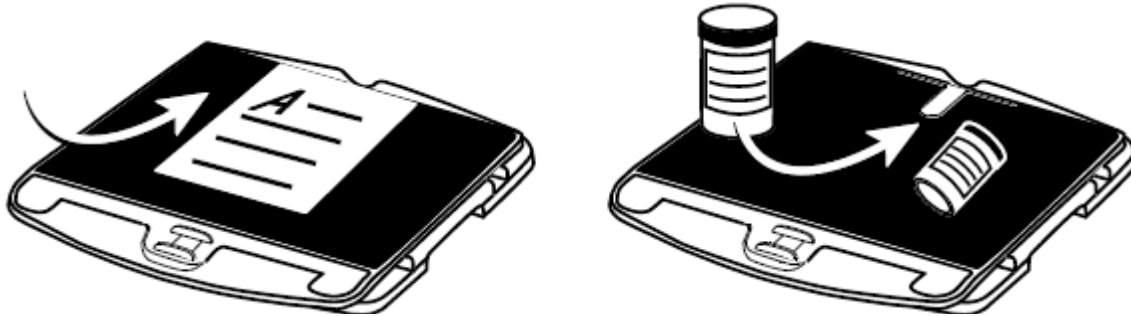

If it is a document, move it back so that it touches the rear of the XY table.

To read a cylindrical item, such as a pill bottle, place it in the indentation located at the rear of the XY table. This prevents the bottle from rolling on the table.

3. Unlock and move the XY table so that the document or item displays on the screen.



Note that when the table is unlocked, you can move it back and forth so that the document's text moves across the screen making reading easier.

Changing Magnification

Turn the **black Magnification dial** clockwise to zoom in or counterclockwise to zoom away from the object that is displayed on the screen.

The unit can display 16 levels of magnification.

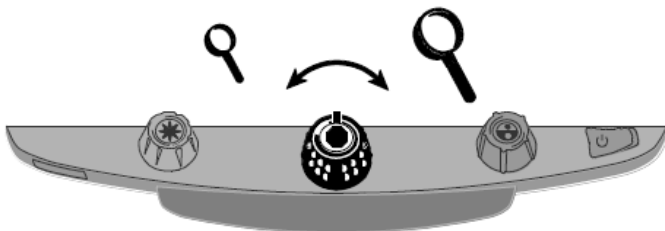

Adjusting Screen and Image Brightness

Turn the **yellow Brightness dial** to adjust brightness.

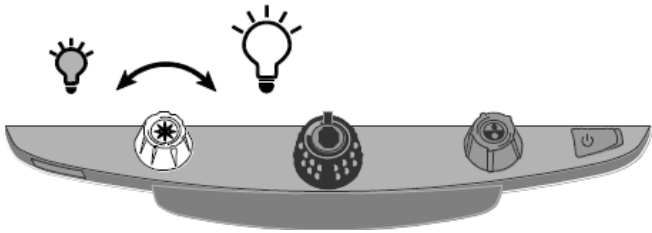

Changing Screen Colors

Turn the **blue Color Select dial** to choose a color mode that best suits your vision needs.

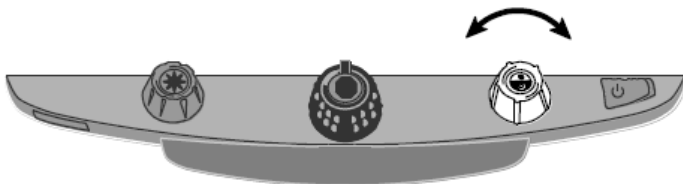

A color mode is a pre-defined color combination (for example, yellow text on a black background). You can use color modes to reduce glare and provide contrast to make it easier to read text on the screen.

There are five default color modes:

- True Full Color – always available, cannot be deleted
- Black on White (high-contrast positive) – always available, cannot be deleted
- White on Black (high-contrast negative) – always available, cannot be deleted
- Yellow on Blue
- Yellow on Black

You can also activate additional color modes. For a complete list, refer to *Color Modes* on page 15. To add more color modes, refer to *Changing Configuration Menu Settings*

Freezing an Image

To freeze the current image that is displayed on the screen, do the following:

1. Press the center of the **black Magnification dial**.

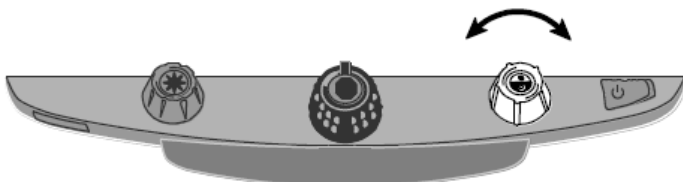

The freeze frame icon appears on the screen: **||**

2. Press it again to turn off Freeze Frame and return to the camera's live view.

Using the Find Feature

The Find feature is useful when moving and repositioning a document or item under the camera. Crosshairs display on the screen to assist with positioning.

1. Press and **hold** the **Find button** located in the center of the **yellow Brightness dial**.

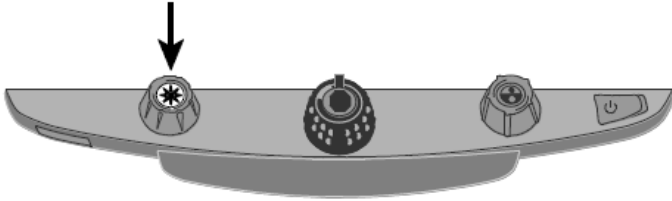

Crosshairs display on the screen (indicating the center of the image on the screen), and the camera zooms out.

2. While still holding the button, move the XY table and use the crosshairs to center and view a new area of the document.

3. Release the **Find button**. 

The camera zooms in to its previous magnification level and the crosshairs turn off.

Locking the Focus

Focus lock keeps the camera focused on the item you are viewing instead of trying to automatically focus on your hand, or any other item that passes in front of the camera. This is useful when working or writing directly under the camera.

In addition to focus lock, the FX-E XL HD has a Position Locator beam that projects a red dot onto the XY table. Use it to help you pinpoint your location on the XY table and what you see on the monitor.

To use Focus Lock, do the following:

1. Press the **red Focus Lock button** once to turn on Focus Lock.

The padlock icon appears on the screen:

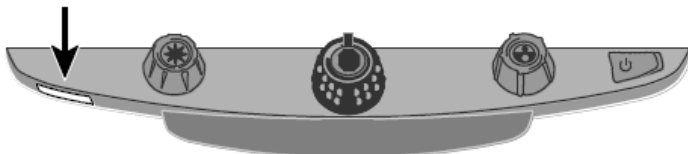

- Press the button a second time to turn on the Position Locator beam and remain in Focus Lock mode.
- Press it a third time to turn off the beam and Focus Lock. Automatic focus is restored.

Advanced Operation

Focus Lock and Position Locator Beam

By default, the camera automatically focuses on the closest object in view. However, if you want focus to remain on a specific object such as a document on the XY table, you can turn on the Focus Lock feature. This prevents the camera from accidentally focusing on your hand or any other item that moves in front of the camera. During normal operation, it is recommended that you leave Focus Lock off.

The Position Locator beam projects a red dot onto the XY table. Use it to help you pinpoint your location on the XY table and what you see on the monitor.

1. Press the red Focus Lock button once to turn on Focus Lock. The padlock icon appears on the screen.
2. Press the button a second time to turn on the Position Locator beam and remain in Focus Lock mode.
3. Press it a third time to turn off both the beam and Focus Lock mode. Automatic focus is restored.

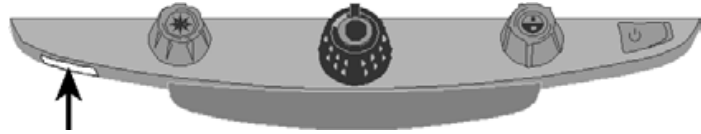

Turning LED Reading Lights On or Off

Note: FX-E has two white LED lights designed to illuminate documents and other items that you place on the reading table. This lighting is diffused to reduce glare and reflections. However, some items, such as photographs or glossy magazine pages, may be too shiny or reflective to view easily. When viewing such items, you can turn off the reading lights if you like.

1. To turn off the LED reading lights, press the center of the yellow Brightness dial and the red Focus Lock button simultaneously.
2. Press both again when you want to turn the reading lights on.

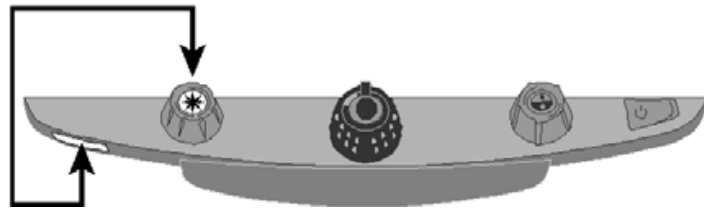

Reading Lines, Masks and Shades

Reading lines display as two horizontal or vertical lines on the screen. Reading masks and shades block part of the screen to show only a horizontal or vertical slice of the screen. Use these items to help you concentrate on a specific area of the object(s) you are examining. You can move either lines or masks together to change their position on the screen, or move one line or mask to adjust the distance between these items.

Note: The switch and dials that control reading lines and reading masks are located under the plastic cover on the bottom of the control panel. Press the two recessed tabs on the backside of the cover to remove it to access the purple switch and dials.

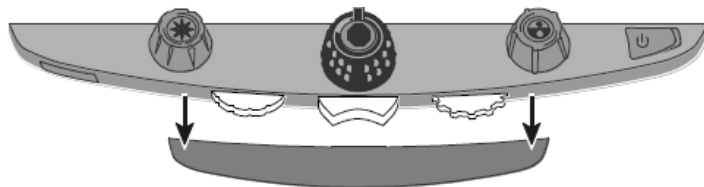

Displaying Lines, Masks, or Shades – Center Switch

Press the **center purple switch** to the right or left to cycle through and display lines, masks, or shades horizontally or vertically on the screen.

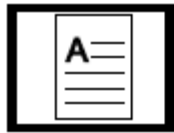

None



Horizontal
Lines



Horizontal
Masks



Horizontal
Shades



Vertical
Lines



Vertical
Masks



Vertical
Shades



None

Moving Lines, Masks, or Shades – Left Wheel

Turn the **left purple Adjustment wheel** to the left or right to move lines, masks, or shades up and down or left and right on the screen.

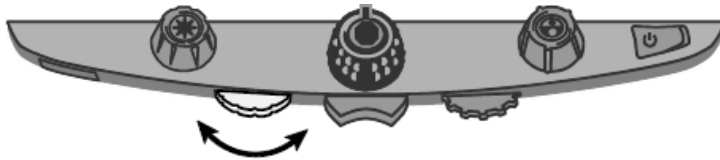

Moving a Single Line, Mask, or Shade – Right Wheel

For horizontal lines, masks, or shades:

Turn the **right purple Width wheel** to the left or right, which moves the top line, mask, or shade up or down. This increases or decreases the distance between horizontal lines, masks, or shades.

For vertical lines, masks, or shades:

Turn the **right purple Width wheel** to the left or right, which moves the right line, mask, or shade to the left or right. This increases or decreases the distance between vertical lines, masks, or shades.

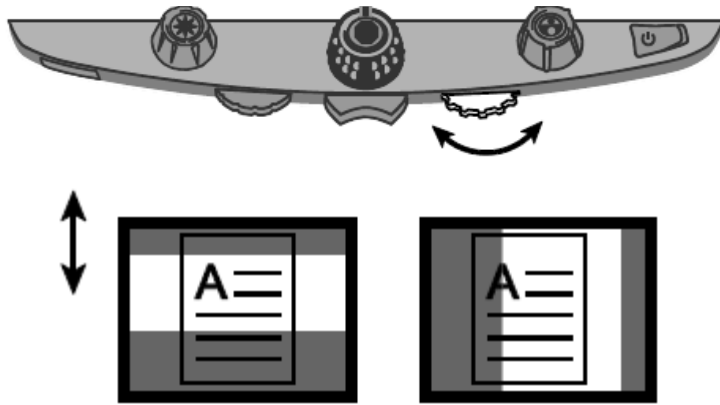

Using the Reading Line

The reading line is a single horizontal line that displays on the screen to help you maintain your place while reading a document. It is useful when using the XY table to scroll your document across the screen.

To use the reading line, do the following:

1. Press the center of the **blue Color Select dial** to place a horizontal line across the screen.

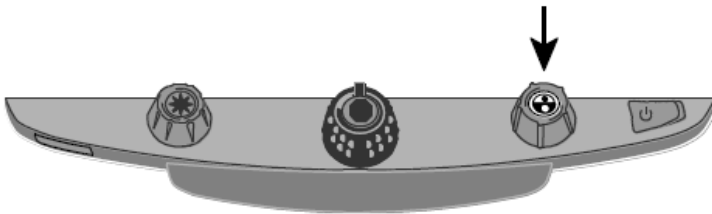

The line displays approximately one third of the way up from the bottom of the screen.

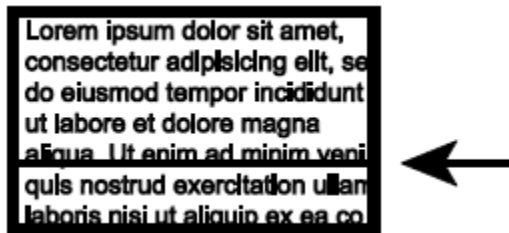

2. Next, move the XY table to the right to continue reading text. To read the next line, move the reading table away from you so that the reading line displays under the next line of text. You can then slide the XY table to the left side of the document to continue reading.

3. To remove the reading line from the screen, press the center of the **blue Color Select dial** again.

Note: This feature is not available when FX-E HD is connected to your computer via the VGA connector. When connected this way, the center of the dial becomes the Computer View Toggle button and switches between computer view and the unit's camera view.

Color Modes

There are five factory default color modes and 28 additional color modes that you can activate and use. Select the color modes that best suit your visual needs, for example, yellow text against a black background.

1.	Full Color ¹	12.	Blue on White	23.	Violet on White
2.	Black on White ¹ (high-contrast positive)	13.	Green on Black	24.	White on Violet
3.	White on Black ¹ (high-contrast negative)	14.	Black on Green	25.	Orange on Black
4.	Yellow on Blue ²	15.	Red on White	26.	Black on Orange
5.	Yellow on Black ²	16.	White on Red	27.	Green on Yellow
6.	Grayscale	17.	White on Green	28.	Yellow on Green
7.	Blue on Yellow	18.	Green on White	29.	Amber on White
8.	Black on Yellow	19.	Black on Blue	30.	White on Amber
9.	Violet on Black	20.	Blue on Black	31.	Black on Amber
10.	Black on Violet	21.	Black on Red	32.	Amber on Black
11.	White on Blue	22.	Red on Black	33.	High-Contrast Full Color

¹ Default color modes for positions 1 through 3; cannot be changed or deleted.

² Default color modes for positions 4 and 5 can be changed or deleted. Maximum 12 positions can be active.

Changing Configuration Menu Settings

You can change the unit's factory settings using the Configuration menu as described in this section.

Note: When configuring color modes, it is best to have both a page of text and a color photo to place under the camera to select settings best suited for you.

1. Press and **hold** the **red Focus Lock button** for approximately 10 seconds to open the Configuration menu. Release the button when the color mode settings display.

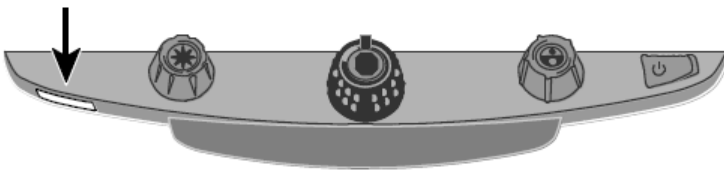

The color mode setting (T) displays in the lower left corner of the screen.

- The hollow outline displays for positions 1-3 and indicates that color settings cannot be changed or disabled
- The solid outline displays for positions 4-12 and indicates that color settings can be edited

2. Turn the **blue Color Select dial** to scroll through positions 4-12.

The color combination currently displayed on the screen is assigned to that position number.

To select and enable a position with its current color mode:









- Press the center of the **black Magnification dial**.
- If you press it again, the position is cleared () and disabled.

To select a position and choose a different color mode:

- Turn the **yellow Brightness dial** to view the 33 color modes.
- When you find a color mode that you want to use, press the center of the **black Magnification dial** to select the color combination and enable the current position.

Repeat this step as necessary to configure other positions.

3. Press the **red Focus Lock button** to move to other settings, which are listed below.

Icon	Description	Default Setting
	Freeze Frame	✓
	Focus Lock	✓
	Home ¹	✗
	Find	✓
	Single Reading Line	✓
	LED Reading Light Brightness	3 (High)
	Magnification Tables ²	1
	Magnification Display Number ²	"88"

¹ See *Restore User Settings When Powering On the Unit* on page 17 for more details.

² See *Adjusting Magnification Settings* on page 23 for more details.

4. When an item that you want to change displays, press the center of the **black Magnification dial** to:

- Select and enable a setting
- Clear and disable a setting
- Cycle through the different options available for a setting

5. When finished, press and **hold** the **red Focus Lock button** for at least 10 seconds to save your new default setting and exit the Configuration menu.

Note: To restore factory default settings, refer to page 18 for more information.

Saving and Restoring User Settings

After enabling or disabling color modes and other settings in the Configuration menu, you can select your favorite color combination and screen brightness settings, and then save all changes as your default user settings. Being able to recall these settings is useful if you decide to experiment with other colors and settings, but are not satisfied with the changes.

Save User Settings

Press and **hold** these control panel buttons simultaneously until the Save icon displays.

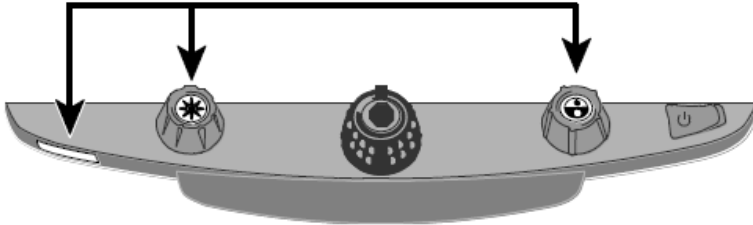

- Red Focus Lock button
- Center of yellow Brightness dial
- Center of blue Color Select dial

Restore User Settings

If it is necessary to restore user settings, press and **hold** these control panel buttons simultaneously for at least 10 seconds.

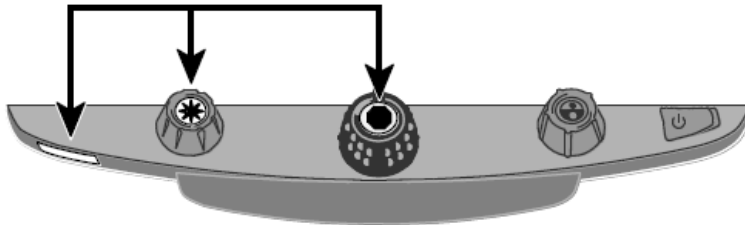

- Red Focus Lock button
- Center of yellow Brightness dial
- Center of black Magnification dial

Restore User Settings When Powering On the Unit

By default, the unit always powers on with the same settings as the previous session, to include color mode, brightness adjustments, and any lines, masks, or shades used.

If you want the unit to always start in a specific color mode and brightness, while also resetting all adjustments made in the prior session, select **Home** in the Configuration menu.

(Home is disabled by default.)

To open the Configuration menu and select **Home**, refer to **Changing Configuration Menu Settings**



After exiting the Configuration menu, save your changes as described earlier.

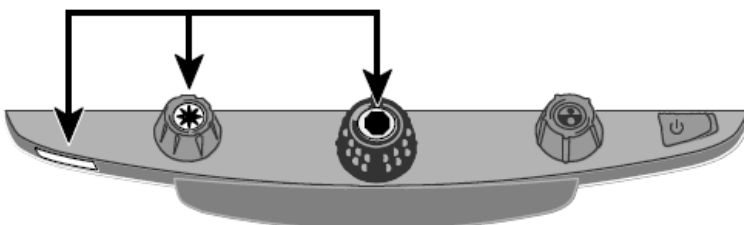

Disabling Center Push Buttons on the Control Panel

To simplify operation, you can disable the center push buttons on the control panel that operate the Freeze Frame ; Find ; and Single Reading Line features. To do this,

1. Press and **hold** the **red Focus Lock button** (bottom left side of the control panel) for at least 10 seconds to open the Configuration menu.

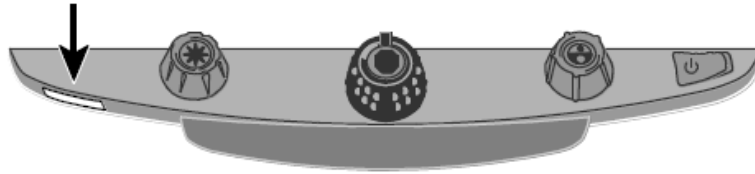

2. Press the **red Focus Lock button** until Freeze Frame displays. It is selected by default.

Press the center of the **black Magnification dial** to clear Freeze Frame.

3. Press the **red Focus Lock button** again to move to the Find setting. It is selected by default.

Press the center of the **black Magnification dial** to clear Find.

4. Press the **red Focus Lock button** again to move to the Single Reading Line setting. The option is selected by default.

Press the center of the **black Magnification dial** to clear the Single Reading Line.

5. When finished, press and **hold** the **red Focus Lock button** for at least 10 seconds to save and exit the Configuration menu.

With the buttons disabled, nothing will happen when you press the center of the **yellow Brightness dial**, the **black Magnification dial**, or the **blue Color Select dial**.

When you restore your user settings or the factory default settings, the buttons and features are enabled again.

Resetting Factory Default Settings

To reset the unit to its default factory settings, press and **hold** the following dials and buttons simultaneously for 10 seconds. Release the dials and buttons when the screen goes blank.

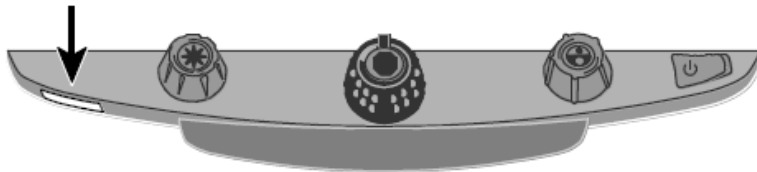

- Red Focus Lock button
- Center of yellow Brightness dial
- Center of black Magnification dial
- Center of blue Color Select dial

Displaying Firmware Version Number



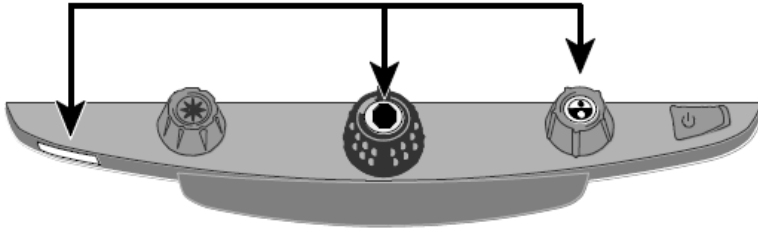

Press and **hold** the following dials and buttons simultaneously for five seconds to display the firmware version number. The word **Ver.** followed by several sets of numbers flash one at a time on the screen. The first three sets indicate the unit's firmware version.





If you need technical assistance, please have this information available before contacting Technical Support.





- Red Focus Lock button
- Center of black Magnification dial
- Center of blue Color Select dial

Appendix A – Configuration Menu Settings

Setting	Description
<p data-bbox="120 258 326 296">Color Select</p> <div data-bbox="139 344 380 443">  </div>	<p data-bbox="431 285 1349 352">Adds more color positions so that additional color combinations are available when you turn the blue Color Select dial during normal operation.</p> <p data-bbox="431 394 1341 459">By default, positions 1 through 5 are available. Positions 6 through 12 can be added using this setting.</p> <p data-bbox="431 499 667 543">Hollow icon – </p> <p data-bbox="431 573 1219 604">Positions 1 through 3 are always available and cannot be changed.</p> <p data-bbox="431 642 1398 709">Position 1 is always full color. Position 2 is black on white (high-contrast positive). Position 3 is white on black (high-contrast negative).</p> <p data-bbox="431 747 654 791">Solid icon – </p> <p data-bbox="431 821 1386 921">Displays for positions 4 through 12. These positions can be added to or removed from normal operation. In addition, you can select one of 33 different color combinations for each position.</p> <p data-bbox="431 961 1357 1029">By default, position 4 is yellow on blue, and position 5 is yellow on black. Both positions can be changed using this setting.</p> <p data-bbox="431 1068 854 1100">Adding and removing Color Modes</p> <p data-bbox="431 1140 1403 1207">To add a position, select it by pressing the center of the black Magnification dial. To remove a position, clear it by pressing the center of the dial again.</p>
<p data-bbox="120 1245 355 1283">Freeze Frame</p> <div data-bbox="228 1329 277 1409">  </div>	<p data-bbox="431 1272 1192 1304">Disables or enables freeze frame functionality. It is enabled by default.</p> <p data-bbox="431 1339 1354 1404">If you disable it, Freeze Frame is no longer available when you press the center of the black Magnification dial during normal operation.</p>
<p data-bbox="120 1455 310 1493">Focus Lock</p> <div data-bbox="224 1549 302 1650">  </div>	<p data-bbox="418 1482 1409 1619">This setting disable or enable focus lock functionality. If you disable the setting, you completely disable focus lock so that it is not available when you press the red Focus Lock button during normal operation. In this case, only the red position locator beam is available when the button is pressed.</p> <p data-bbox="418 1659 948 1690">The Focus Lock setting is selected by default.</p> <p data-bbox="418 1730 1409 1831">When using the unit, the camera automatically focuses on the closest object in view. However, if you want focus to remain on a specific object such as a document on the XY table, you can turn on Focus Lock by pressing the red Focus Lock button.</p> <p data-bbox="418 1871 1414 1971">This prevents the camera from accidentally focusing on your hand or any other item that moves in front of the camera. During normal operation, it is recommended that you leave Focus Lock off.</p>

Setting	Description
<p>Home</p> 	<p>This setting is cleared by default. When cleared, the unit will always turn on using the same color, brightness, and reading lines or mask settings as in your last session.</p> <p>When selected, the Home setting resets the unit to your default user settings every time you turn on the unit. Your default settings can be what you choose in the Configuration menu, or what you set and save later during normal operation.</p>
<p>Find</p> 	<p>During normal operation, Find displays a set of crosshairs on the screen and zooms out so that you can see more of the item displayed on the screen.</p> <p>This setting is enabled by default. If you disable it, Find is no longer available when you press the center of the yellow Brightness button during normal operation.</p>
<p>Single Reading Line</p> 	<p>This setting is selected by default. It allows you to display a horizontal line across the bottom third of the screen during normal operation. Use it to help you maintain your place when reading a document.</p> <p>When cleared, the line does not display when you press the center of the blue Color Select dial during normal operation.</p>
<p>LED Reading Lights</p> 	<p>The LED reading lights can be set to one of three brightness intensity levels:</p> <ul style="list-style-type: none"> Low (1) Medium (2) High (3) <p>By default, the brightness level is set to high (3).</p> <p>Press the center of the black Magnification dial to select a brightness level.</p>

Setting	Description
<p data-bbox="120 130 360 218">Magnification Levels</p> 	<p data-bbox="431 155 1360 218">The unit can display 16 levels of magnification when you turn the black Magnification dial (positions 1 to 16).</p> <p data-bbox="431 254 1321 317">Three separate magnification tables are available for use. Each table offers slightly different values so that you can choose the best magnification power for you.</p> <p data-bbox="431 352 1170 380">Table 1 is the default magnification table and is ideal for most users.</p> <p data-bbox="431 415 1292 478">Table 2 is best if you are comfortable with lower magnification. It provides finer adjustments between positions 1 through 5.</p> <p data-bbox="431 514 1382 577">Table 3 provides finer adjustments in the middle magnification range available between positions 6 through 10. This table is good if you need greater magnification.</p> <p data-bbox="431 613 1214 640">Press the center of the black Magnification dial to select table 1, 2, or 3.</p>
<p data-bbox="120 781 360 919">Magnification Display Number</p> 	<p data-bbox="431 808 1349 871">Sets the type of magnification value that displays on the screen as you turn the black Magnification dial.</p> <p data-bbox="431 907 1133 934">Press the center of the black Magnification dial to select a value.</p> <p data-bbox="431 970 1312 1033">Select the icon with “88” to display the magnification in use relative to the 16 dial positions, for example, 1, 2, 3, 14, 15, 16.</p> <p data-bbox="431 1068 1377 1131">Select the icon with the clear magnifying glass if you do not want to see a magnification value display as you turn the dial.</p> <p data-bbox="431 1146 1369 1209">Select the icon with “X” to display the actual magnification value, for example, 3.7, 6.4, 13, and so on.</p>

Appendix B – Adjusting Magnification Settings

Note: The following advanced feature is intended for sales and support personnel. It is accessed in the Configuration mode.

The unit can display 16 levels of magnification. To increase magnification, turn the **black Magnification dial** clockwise. To decrease magnification, turn it counterclockwise.

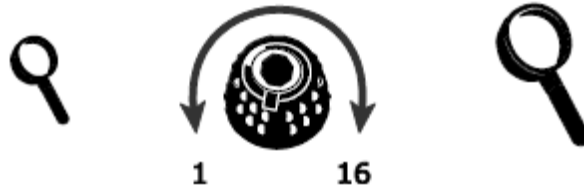

To get the most out of the unit, there are three magnification tables from which you can choose the best magnification power for you.

- **Table 1** is the default magnification table and is ideal for most users. Turn the black **Magnification dial** to step through positions 1 through 16.
- **Table 2** is ideal if you are comfortable with lower magnification. It provides finer adjustments between positions 1 through 8.
- **Table 3** provides finer adjustments for midrange magnification available between positions 8 through 14. This table is good if you need greater magnification.

Experiment with the different magnification tables and use the one that is best for you. You can always revert to table 1 at any time if you are not comfortable with the magnification available in tables 2 and 3. The following describes how to select and edit your viewing preferences.

Selecting a Magnification Table

1. Press and hold the **red Focus Lock button** for approximately 10 seconds until the letter **T** displays in the lower left corner of the screen.
2. Continue to press the **red Focus Lock button** until the video magnification icon displays on the screen.
3. Press the center of the **black Magnification dial** to select one of the three magnification tables.
4. Do one of the following:
 - To save the change and exit configuration mode, press and hold the **red Focus Lock button** for approximately 10 seconds until the on-screen display at the bottom of the screen closes.
 - To customize how magnification values display on the screen, perform the steps in the next section.

Changing the Magnification Display Number

Once you have selected a magnification table, you can choose whether or not the current magnification value displays on the screen as you turn the **black Magnification dial**. To set your preference, do the following:

1. Press the **red Focus Lock button** until the magnifying glass icon displays on the screen.
2. Press the center of the **black Magnification dial** to select how magnification values display. This is represented by the magnifying glass icon.



Select to display the magnification in use relative to the 16 positions of the **black Magnification dial**, for example, 1, 2, 3, ..., 14, 15, 16.



Select if you do not want any magnification value to display as you turn the **black Magnification dial**.



Select to display the actual magnification value, for example, 3.7, 6.4, 13, and so on.

3. To save changes and exit configuration mode, press and hold the **red Focus Lock button** for approximately 10 seconds until the on-screen display at the bottom of the screen closes.

To discard any changes made while configuration mode is open, do not touch any control panel dials, buttons, switches, or wheels for approximately 30 seconds. This closes configuration mode without saving changes.

Appendix C – Using FX-E XL HD as a Computer Monitor

Connecting Computer to FX-E

You can connect FX-E directly to your computer and use it as your primary monitor. When connected, you can always switch back to the camera view by pressing the center of the **blue Color Select dial**.

Important: Connecting the unit to a computer requires a 15-pin VGA video cable. Count the number of pins, and make sure the video cable has all 15 pins. Anything less will not work.

1. Power off both the unit and your computer.
2. Connect one end of a 15-pin VGA (video) cable to the video port on your computer. Refer to your computer documentation for the location of this port. Connect the other end of the cable to the VGA connector on FX-E.

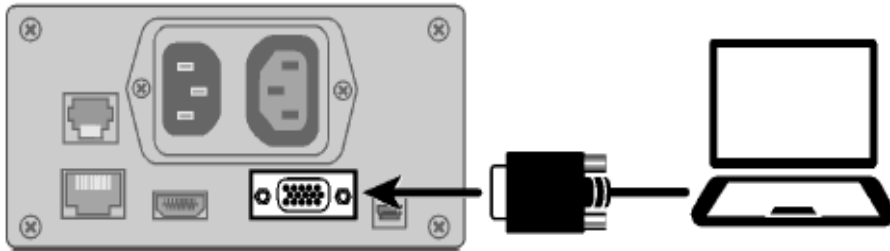

3. Power on FX-E and then your computer.

The video signal from your computer now goes to FX-E, making it your computer monitor.

4. When using a laptop computer, make sure to turn on the laptop's VGA port. This is typically done by pressing and holding the **Fn** key along with one of the function keys ranging from **F1** to **F12**. Refer to your computer documentation for the correct function key.

Pressing this key combination usually cycles between seeing what appears only on the laptop screen, the FX-E's screen, and both screens simultaneously.

5. Press the center of the **blue Color Select dial** to cycle the view between your computer and the FX-E camera. The computer view displays what you are running on your computer. The camera view displays items that are on the XY table.

When the camera view displays on the FX-E monitor, you can use all FX-E functionality. This includes changing magnification, selecting different color modes, changing brightness, and so on.

When the computer view displays on the FX-E monitor, FX-E functionality is disabled.

Note: If the image on your monitor is distorted in some way, for example, the screen is compressed horizontally or is skewed, or the screen is wavy, dull, or flickering, you may need to change the current screen resolution set on your computer as described in the next section.

Screen Resolutions

The following screen resolutions supported for the following FX-E XL HD models. The shaded cell indicates the recommended settings.

FX-E HD 24-inch monitor
720 x 400p at 70 Hz
640 x 480p at 60 Hz
800 x 60 Hz0p at 60 Hz
1024 x 768p at 60 Hz
1024 x 768p at 70 Hz
1152 x 864p at 75 Hz
1280 x 800p at 60 Hz
1280 x 1024p at 60 Hz
1440 x 900p at 60 Hz
160 Hz0 x 1200p at 60 Hz
160 Hz0 x 1200p at 60 Hz

Appendix D – Making a USB Connection to FX-E

GEM® image management software lets you view, capture, and save magnified images from FX-E to your computer. You can quickly and easily step through or jump to multiple images captured by the software. To use the GEM, refer to the software documentation.

Note: Connecting FX-E to a computer requires a cable with a USB Mini-B plug.

1. To connect FX-E to a computer, connect the USB Mini-B plug into the USB connector on the back of FX-E.

The video signal and camera image from FX-E goes directly to your computer. The FX-E view is visible using the GEM software.

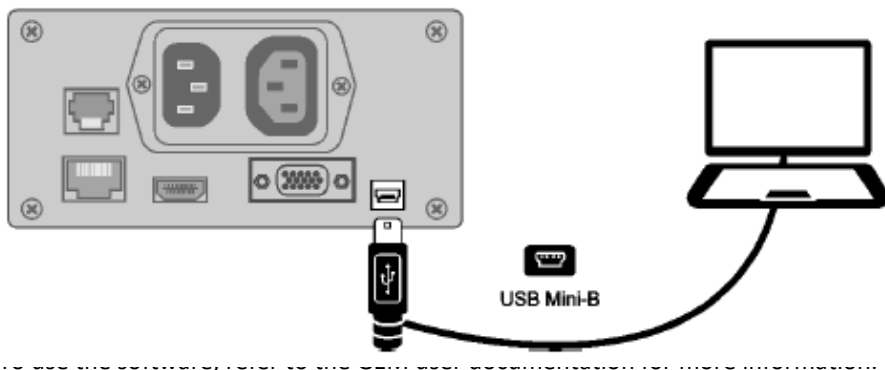

Appendix E – Troubleshooting

Problem	Likely Solution
The screen is blank.	<p>Press the unit's power button.</p> <p>Make sure the power cable is correctly connected to the unit and a power outlet.</p> <p>Reduce magnification.</p> <p>Adjust brightness.</p> <p>Switch to a different color mode.</p>
The unit does not power on.	<p>Press the unit's power button.</p> <p>Make sure the power cable is correctly connected to the unit and a power outlet.</p> <p>Ensure that the power outlets have power and are not malfunctioning. If the outlets are connected to a wall switch, make sure that the switch is on.</p>
The image on the screen is not changing.	<p>Press the red Freeze Frame button to return to live view.</p>
The image on the screen is too bright, or there is a glare from the screen that makes it difficult to see.	<p>Reduce brightness.</p> <p>Switch to a different color mode.</p>
The image on the screen is too dark.	<p>Increase brightness.</p> <p>Switch to a different color mode.</p>
The unit does not power on with my user settings.	<p>Ensure that the Home setting is enabled.</p>
There are smudges or blemishes on the screen.	<p>Clean the screen using a damp, soft, lint-free cloth.</p>

Appendix F – GEM Software User's Guide

PUBLISHED BY Freedom Scientific 11800 31st Court North St. Petersburg, Florida 33716-1805 USA
www.FreedomScientific.com

Information in this document is subject to change without notice. No part of this publication may be reproduced or transmitted in any form or any means electronic or mechanical, for any purpose, without the express written permission of Freedom Scientific.

GEM®, TOPAZ®, ONYX®, and OpenBook® are registered trademarks of Freedom Scientific, Inc., in the United States and other countries.

FX-E is a registered trademark of SIRCHIE, in the United States and other countries.

Copyright © 2016 Freedom Scientific, Inc. All Rights Reserved.

Freedom Scientific Technical Support for GEM

To contact **Technical Support** by telephone, U.S. customers can call **(727) 803-8000**, Monday through Friday, 8:30 AM to 7:00 PM (Eastern Time).

To contact by e-mail, send questions to **Support@FreedomScientific.com**.

To search the knowledge base, visit **www.FreedomScientific.com** and choose the Support link.

Introduction to GEM

GEM® allows you to view, capture, and save magnified images when using the FX-E with your computer.

Using hot keys or the graphical user interface, you can quickly and easily step through or jump to multiple images captured by GEM. Groups of images can automatically be saved to any designated folder on your computer. These same images are easily identified using either the default or customized base name along with a time stamp. Hot key input directly from your computer keyboard allows you to manipulate camera views, change magnification, select color modes, and control other camera functions on the fly.

System Requirements

Your computer needs the following minimum system requirements to run GEM.

- Microsoft Windows® 10, Windows 8.1, or Windows 7 operating systems
- 1 GHz or faster processor
- 1 GB RAM (32-bit) or 2 GB RAM (64-bit)
- 60 MB available hard disk space for program installation
- DirectX® 9.1 graphics device with WDDM 1.0 driver or later
- USB 2.0 port for connection to the desktop magnifier camera

Installing GEM

To install GEM on your computer, do the following:

Important: Do not connect the FX-E to your computer until the GEM installation is complete. For more information on using FX-E, refer to the FX-E User's Guide.

1. Insert the GEM program disk into your computer.
2. The GEM Setup program starts. Follow the instructions that display on your screen to complete the installation.

Note: If the setup program does not start automatically, go to the Start button, select Run, and type D:\setup. If your disk drive is not D, substitute the correct drive letter.

3. Choose the Typical installation to install GEM to the default location on your hard drive. Select the Custom installation if you want to install GEM in a location other than the default.
4. Once the installation is complete, turn on the FX-E and connect it to an available USB port on your computer.
5. Start GEM by selecting the GEM icon from the desktop to begin using the application with FX-E.

Getting Help

Press **F1**, or choose Help Topics from the Help menu to open the help file.

To display context-sensitive help for the item selected in the GEM window, do any of the following:

- Press **SHIFT+F1**
- Right-click the selected item
- Use the Question Mark button in the upper right corner of a dialog box

GEM Hot Keys

A hot key is a keyboard shortcut you can use to perform an action. Hot keys are an alternative to using the GEM user interface with your mouse.

The GEM hot keys use the **F12** modifier, which is the application's default modifier key. You must press the modifier key in combination with the hot key to activate the command. If you change the default modifier key (for example, to **F11**, **Scroll Lock**, or **Print Screen**), substitute the modifier key that you are using when issuing a command. To change the modifier key, choose the Advanced menu and then General Preferences from the GEM menu bar. Next, select a value in the GEM Key list.

Layered Keystrokes

GEM also supports layered keystrokes, which offer another fast and convenient way to perform GEM actions.

To use a layered keystroke, press and release **F12 +SPACEBAR**, followed by the keystrokes listed in the Layered Keystroke columns in the following tables.

Screen View

Use these hot keys to select, arrange, and view the magnifier's display screen or the computer display screen.		
Select one of three views: Full Screen – Camera view; Full Screen – Computer view; or Split Screen view	F12+V (add SHIFT to move in reverse order)	Layered Keystroke None

Description	Hot Key	Layered Keystroke (F12+SPACEBAR)
Full Screen – Camera view	F12+HOME	V, HOME
Full Screen – Computer view	F12+END	V, END
Split Screen view	F12+PAGE UP	F8 or V, PAGE UP
Video Select Monitor – moves screen view between multiple monitors	F12+PAGE DOWN	V, PAGE DOWN
Split Screen orientation – toggle the Split Screen view between horizontal and vertical orientation. Use this keystroke in conjunction with F12+F to change camera view locations	F12+P	SLASH, P or SLASH, O
Move Split Screen view – toggle the camera position to move the Split Screen view from top to bottom or from left to right based on screen orientation (F12+P)	F12+F	SLASH, F
Increase Split Screen viewing area	F12+F6	SLASH, EQUALS or SLASH, NUMPAD PLUS
Decrease Split Screen viewing area	F12+F5	SLASH, DASH or SLASH, NUMPAD MINUS
Move GEM user interface to foreground	F12+ENTER	ENTER
Scroll image down or right while in Split Screen mode	F12+F7	I, DOWN ARROW

Capture Image

Use these hot keys to capture and delete images.

Description	Hot Key	Layered Keystroke (F12+SPACEBAR)
Save current image displayed on screen	F12+CTRL+S	F5
Capture image and return to live view	F12+I	I, I
Capture image and remain on screen	F12+TAB	SHIFT+F5 or I, TAB
Capture and Send current image to OpenBook	F12+DASH	F4 or R, 1
Send all selected images to OpenBook	F12+CTRL+DASH	R, A
Delete image	F12+DELETE	I, DELETE
Remove image from Manage Image list	F12+Q	I, Q

View Image

Use these hot keys to open images from the Manage Images dialog box or to display the live camera image. The selected image becomes the current image and displays when using Split Screen view or Full Screen – Camera view.

Description	Hot Key	Layered Keystroke (F12+SPACEBAR)
Jump to live image	F12+0 (zero)	I, 0 (zero)
Next image	F12+RIGHT ARROW	I, RIGHT ARROW
Previous image	F12+LEFT ARROW	I, LEFT ARROW
Jump to image 1 (most recent image)	F12+1	SHIFT+F6 or I, 1
Jump to image 2	F12+2	I, 2
Jump to image 3	F12+3	I, 3
Jump to image 4	F12+4	I, 4
Jump to image 5	F12+5	I, 5
Jump to image 6	F12+6	I, 6
Jump to image 7	F12+7	I, 7
Jump to image 8	F12+8	I, 8

Zoom and Focus

Use these hot keys to do the following:

- Zoom in or out when using Split Screen view or Full Screen – Camera view
- Switch Focus Lock on or off. When off, the camera automatically focuses on the closest object. When on, as indicated by the padlock icon on the magnifier's screen, the camera does not adjust its focus.
- Freeze an image and view it using Split Screen view or Full Screen – Camera view

Description	Hot Key	Layered Keystroke (F12+SPACEBAR)
Increase zoom	F12+F2	UP ARROW or I, EQUALS or I, NUMPAD PLUS
Decrease zoom	F12+F1	DOWN ARROW or I, DASH or I, NUMPAD MINUS
Focus lock – cycle between Off, On, and On with Position Locator Beam	F12+D	CTRL+J or I, D
Freeze Frame toggle	F12+Z	CTRL+F or I, Z

Color Modes

Use these hot keys to switch to different color combinations. This is visible when using Split Screen view or Full Screen – Camera view.

Description	Hot Key	Layered Keystroke (F12+SPACEBAR)
Select next color mode – cycles between all available color modes	F12+E	C, RIGHT ARROW
Select previous color mode	F12+SHIFT+E	C, LEFT ARROW
Normal (full color) mode	F12+SHIFT+A	F1 or C, A
User selectable (default is yellow on blue mode)	F12+SHIFT+S	C, S
Black on white mode	F12+SHIFT+D	F2 or C, D
White on black mode	F12+SHIFT+F	F3 or C, F

Color Adjustments

Use these hot keys to change brightness, hue, saturation, and contrast of the live or captured image. This is visible when using Split Screen view or Full Screen – Camera view.

Description	Hot Key	Layered Keystroke (F12+SPACEBAR)
Increase brightness	F12+T	None
Decrease brightness	F12+SHIFT+T	None
Increase hue	F12+H	None
Decrease hue	F12+SHIFT+H	None
Increase saturation	F12+U	None
Decrease saturation	F12+SHIFT+U	None
Increase contrast	F12+C	None
Decrease contrast	F12+SHIFT+C	None

Camera Control

Use these hot keys to control camera settings. The camera is part of the desktop magnifier.

Description	Hot Key	Layered Keystroke (F12+SPACEBAR)
Select camera	F12+S	None
Increase camera brightness	F12+B	RIGHT ARROW or B, EQUALS or B, NUMPAD PLUS
Decrease camera brightness	F12+SHIFT+B	LEFT ARROW or B, DASH or B, NUMPAD MINUS
Turns LED reading lights on and off	F12+L	None
Power selected camera on or off	F12+X	None

Lines and Masks

Use these hot keys to control screen markers such as reading lines and screen masks. These markers can help you maintain your place when reading documents on the screen. These markers are visible in Split Screen view and Full Screen – Camera view.

Description	Hot Key	Layered Keystroke (F12+SPACEBAR)
Screen markers – toggle on or off	F12+K	M, K
Screen marker style – toggle between reading lines or screen masking	F12+Y	M, Y
Screen marker orientation – toggle between horizontal or vertical screen marker orientation	F12+O	M, O
Move reading lines or screen mask down or to the right	F12+N	CTRL+DOWN ARROW or CTRL+RIGHT ARROW or M, DOWN ARROW or M, RIGHT ARROW
Move reading lines or screen mask up or to the left	F12+SHIFT+N	CTRL+UP ARROW or CTRL+LEFT ARROW or M, UP ARROW or M, LEFT ARROW

Increase distance between reading lines or increase amount of image viewable in the masked area	F12+F10	M, EQUALS or M, NUMPAD PLUS
Decrease distance between reading lines or decrease amount of image viewable in the masked area	F12+F9	M, DASH or M, NUMPAD MINUS
Select next reading line color	F12+R	L, RIGHT ARROW
Select previous reading line color	F12+R+SHIFT	L, LEFT ARROW
Increase reading line thickness	None	L, EQUALS or L, NUMPAD PLUS
Decrease reading line thickness	None	L, DASH or L, NUMPAD MINUS

END OF DOCUMENT