TECHNICAL INFORMATION

Fingerprint Bench Assembly

Catalog Nos. FPT-Series and PFT-Series (all inclusive)

INTRODUCTION

Use these instructions for assembly of all SIRCHIE fingerprint benches. **Note:** *Inspect all cartons for damage. If damage is found, contact the delivery carrier immediately.*

Carefully unpack the carton(s) and check for all parts against the list at the end of these instructions to insure that you have everything needed for assembly. If a part is found to be missing, please contact the factory for prompt service. Assembly should be done on a clean, soft cloth or other nonabrasive surface.

PROCEDURE

For All Bench Assemblies

1. Assemble divider insert to center divider with four 6-32 x 1/4" pan head screws (Fig. 1).

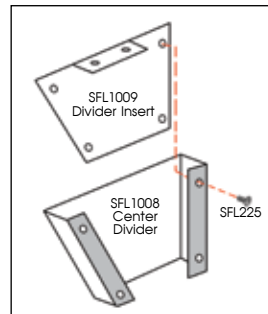

FIGURE 1

TI02-134ENG-REV4

2. Assemble center divider assembly to bottom with three 6-32 x 1/4" pan head screws (Fig. 2).
3. Lay the top upside down on the work surface. Attach the end caps with two 6-32 x 3/8" black pan head screws, #6 washers and 6-32 hex nuts. Slide the two end panels in place on the assembled bottom. Set this entire bottom assembly onto the studs protruding from the top. Secure with eight #6 lock washers and 6-32 hex nuts (Fig. 3).

For Table Model Benches
(FPT274A, FPT274PIP,
FPT275A, FPT275APIP,

PFT100A, PFT100APF, PFT100ACM, PFT200A, PFT200APF, PFT200ACM)

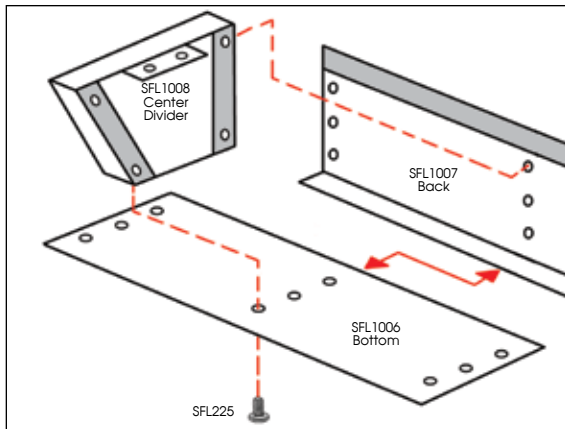

FIGURE 2

- 4a. With the unit upside down, secure the end panels to the back with six 6-32 x 1/4" pan head screws. Secure the end panels to the bottom with four 6-32 x 5/8" pan head screws. Attach the rear feet with two 6-32 x 5/8" pan head screws. Attach the front feet with two #6 x 5/8" sheet metal screws. The unit is now ready for use (Fig. 4a). **NOTE:** *Optional wall mount configuration also shown.*

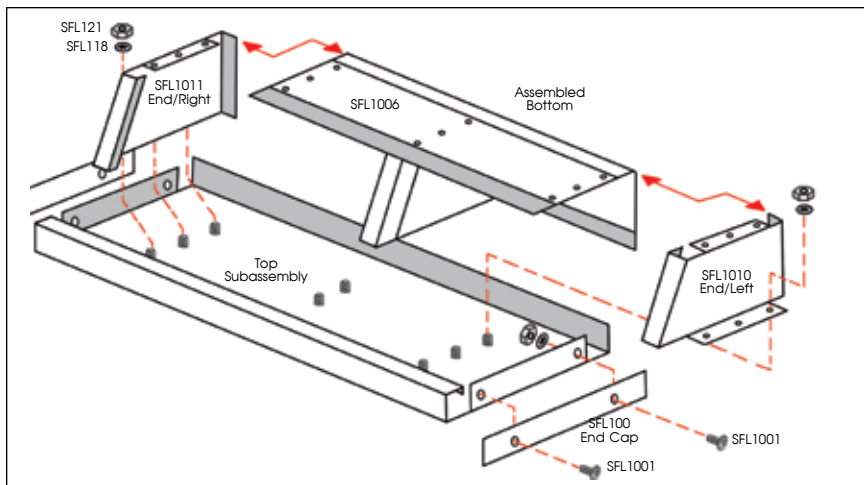

FIGURE 3

For Column Mount Benches
 (FPT400S, FPT400SPIP, FPT500S, FPT500SPIP, FPT200P, FPT200PPF, FPT200PCM, FPT300P,
 FPT300PPF, FPT300PCM)

Note: The column must be assembled prior to the next step. Refer to the bench pedestal assembly instructions on Page 5.

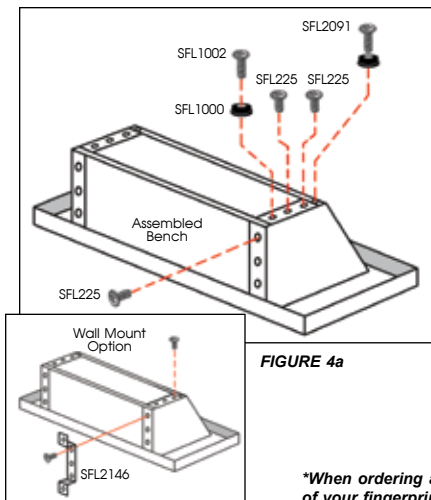

FIGURE 4a

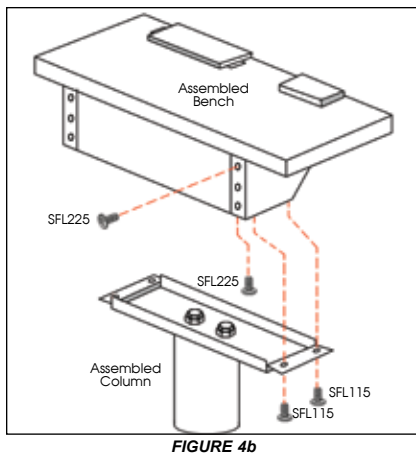

FIGURE 4b

****When ordering a Top Subassembly, you MUST include the Model Number of your fingerprint bench.***

4b. Place the unit in an upright position. Secure the end panels to the back with 6-32 x 1/4" pan head screws and tighten. Place the assembled column on a level surface. Place the bench on top of the column with the front of the bench facing the tabs on the column top. Secure the bench to the column using four 6-32 x 3/8" pan head screws. Secure the end panel to the bottom with two 6-32 x 1/4" pan head screws. Your unit is now ready for use (Fig. 4b).

BENCH PEDESTAL ASSEMBLY INSTRUCTIONS

Note: Check for damage upon receipt of Fingerprint Bench Pedestal and report any to delivering carrier.

Open all boxes and carefully remove contents. Check against list on back page for all necessary parts to construct the base. If any parts are missing, contact the factory for prompt service.

1. Carefully unwrap all parts and hardware. Be sure to work on a piece of carpet, cloth or other nonabrasive surface.
2. Place the base face-up on the work surface. Screw the two (2) threaded rods into the base so that they protrude through the bottom about 1/2" (13mm). Place the column over the threaded rods (Fig. A).
3. Place the mounting plate on top of the column so the threaded rods protrude through the two (2) holes in the plate. Insert a lock washer and an acorn nut on each rod and tighten. Continue to tighten the acorn nuts which in turn tightens the rods into the base until entire assembly is sturdy (Fig. B).
4. Turn the column assembly upside down. Place a lock washer and hex nut on the threaded rods and tighten (Fig. C). Return the assembly upright. Your base is ready to accept the fingerprint bench.

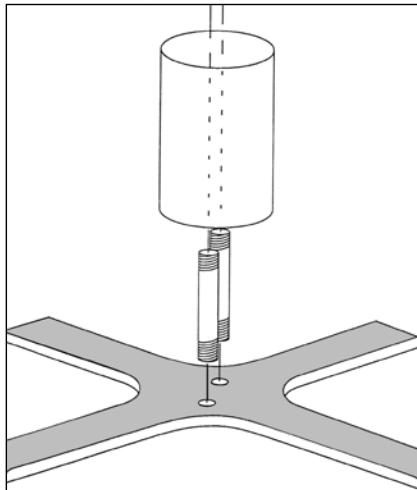

FIGURE A—Place column over threaded rod.

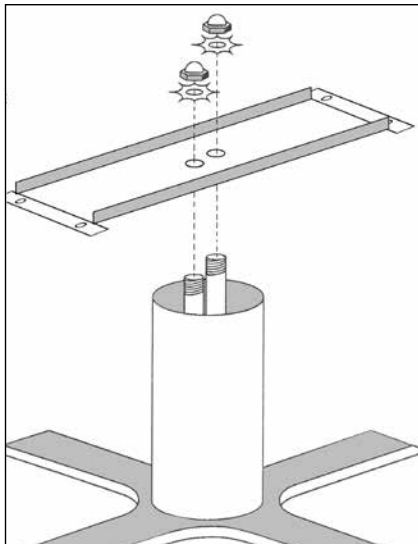

FIGURE B—Attach mounting plate to column.

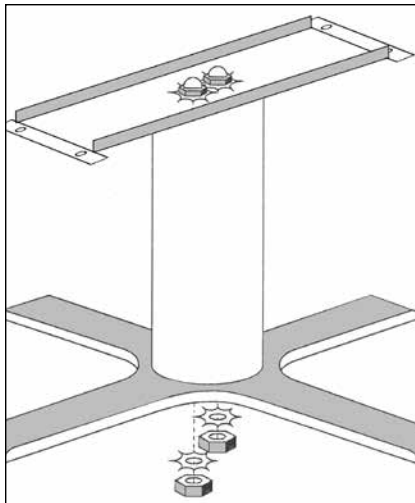

FIGURE C—Secure rods through bottom of base.

**FPT274A, FPT274PIP, FPT275A,
FPT275APIP, PFT100A, PFT100APF,
PFT100ACM, PFT200A, PFT200APF,
PFT200ACM CONTENTS:**

- 1-SFL? Top Sub-Assembly*
- 1-SFL1006 Bottom
- 1-SFL1007 Back
- 1-SFL1008 Center Divider
- 1-SFL1009 Divider Insert
- 1-SFL1010 End Panel, left
- 1-SFL1011 End Panel, right
- 2-SFL1005 End Caps
- 4-SFL1000 Rubber Feet
- 20-SFL225 6-32 x 1/4" Pan Head
Screws
- 4-SFL1001 6-32 x 1/4" Pan Head
Screws (black)
- 2-SFL1002 6-32 x 5/8" Pan Head
Screws
- 2-SFL2091 #6 x 5/8" Sheet Metal
Screws
- 12-SFL118 #6 Internal Star Lock
Washer
- 12-SFL121 6-32 Hex Nuts

**FPT400S, FPT400SPIP, FPT500S,
FPT500SPIP, FPT200P, FPT200PPF,
FPT200PCM, FPT300P, FPT300PPF,
FPT300PCM CONTENTS:**

- 1-SFL? Top Sub-Assembly*
- 1-SFL1006 Bottom
- 1-SFL1007 Back
- 1-SFL1008 Center Divider
- 1-SFL1009 Divider Insert
- 1-SFL1010 End Panel, left
- 1-SFL1011 End Panel, right
- 2-SFL1005 End Caps
- 18-SFL225 6-32 x 1/4" Pan Head
Screws
- 2-SFL2146 Wall Mount Brackets
- 4-SFL115 6-32 x 3/8" Pan Head
Screws
- 4-SFL1001 6-32 x 1/4" Pan Head
Screws (black)
- 12-SFL118 #6 Internal Star Lock
Washer
- 12-SFL121 6-32 Hex Nuts

BENCH PEDESTAL CONTENTS:

- 1-SFL136 Base
- 1-SFL828 Column
- 1-SFL2160 Column Mount
- 2-SFL829 Threaded Rods
- 4-SFL176 3/8" Lock Washer
- 2-SFL174 3/8"-16 Hex Nut
- 2-SFL173 3/8"-16 Acorn Nut
- 4-SFL1001 6-32 x 3/8 Pan Head
Philips Machine Screws (black)

**When ordering a Top Subassembly, you MUST include the Model Number of your fingerprint bench.*



100 HUNTER PLACE, YOUNGSVILLE, NC 27596 USA

919-554-2244 • 800-356-7311

www.sirchie.com